

Installation and Setting-Up Instructions Spare Parts List



Contents:

1 INSTALLATION

- 1.1 Mechanical installation
- 1.2 Electrical connections

2 SETTING UP

- 2.1 Using the Hart® 275 user interface
- 2.2 Setting up through HART® 275 user interface
- 2.3 Using the Hart® 375 user interface
- 2.4 Setting up through HART® 375 user interface
- 2.5 Setting up with Satron-pAdvisor Service Software and Satron SI-Tool_e USB-Hart modem

3 CONSTRUCTION AND OPERATION

4 PARTS LIST

DOCUMENTS

Technical Specifications: BPV711

Installation and Setting-Up Instructions:BPV711AV

We reserve the right for technical modifications without prior notice.
HART® is a registered trademark of HART Communication Foundation.
Hastelloy® is the registered trademark of Haynes International.
Viton® is the registered trademark of DuPont Down Elastomers.



Satron Instruments Inc.

P.O.Box 22, FIN-33901 Tampere, Finland
Tel.int. +358 207 464 800, Telefax +358 207 464 801
www.satron.com, info@satron.com

1. INSTALLATION AND PUTTING INTO OPERATION

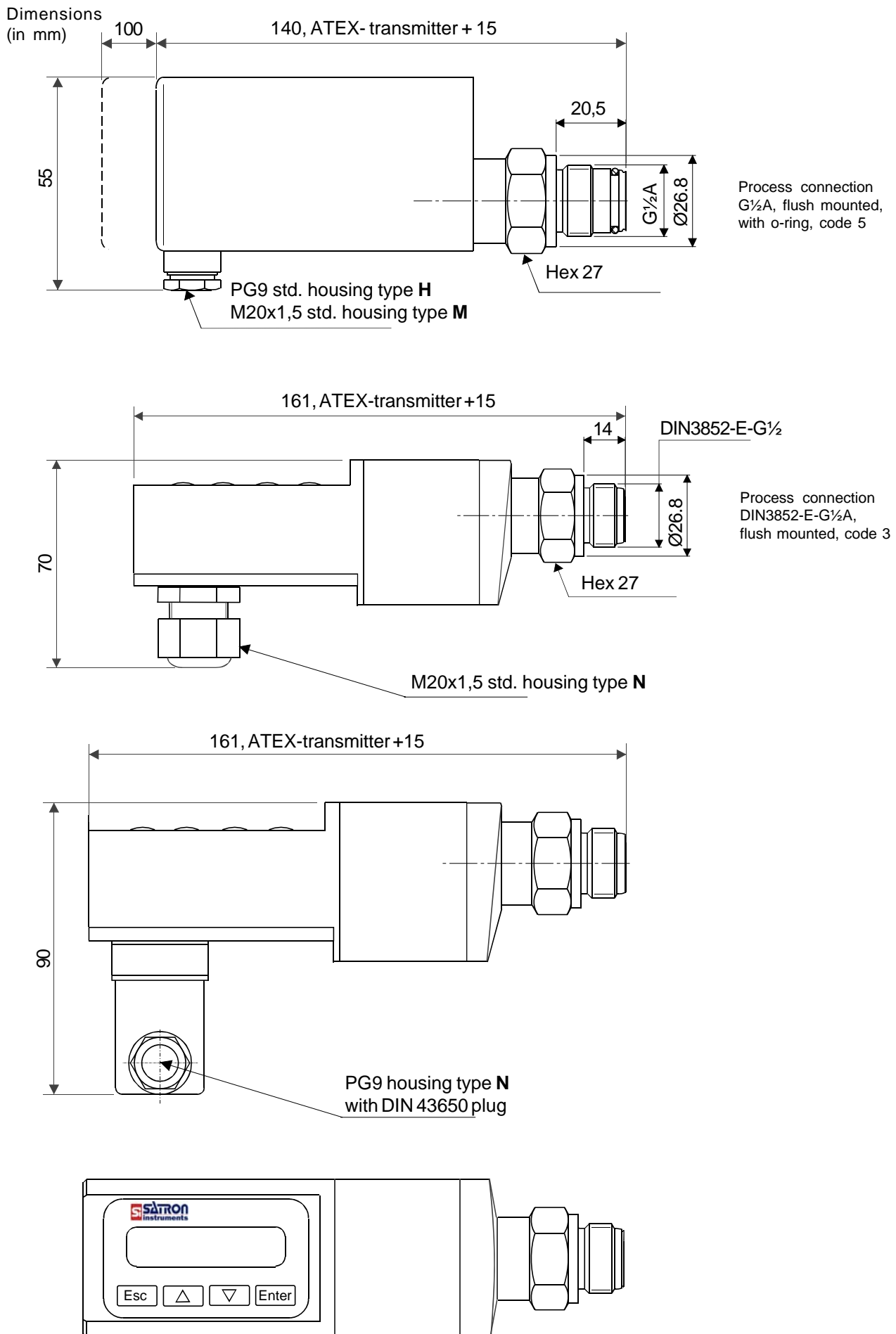
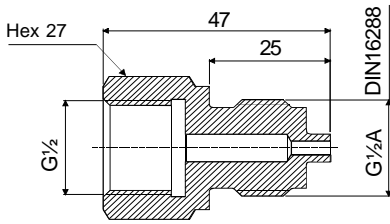
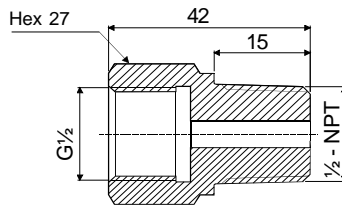

Figure 1-1a Basic mounting dimensions



Thread DIN16288 - G $\frac{1}{2}$ A
Order code : T1320291



Thread $\frac{1}{2}$ - 14 NPT, male
Order code : T1320293

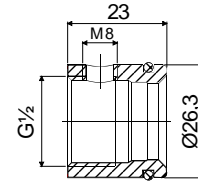

PMC 1" (Ø26,3), for process connection code 5
Order code : T1320310

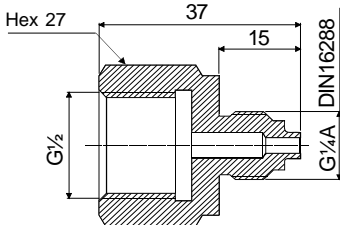

Thread DIN16288 - G $\frac{1}{4}$ A
Order code : T1320292

The process connection of the flush mounted transmitters can be changed using modification adapters.

Other adapter sizes, please contact to Satron Instruments Inc.

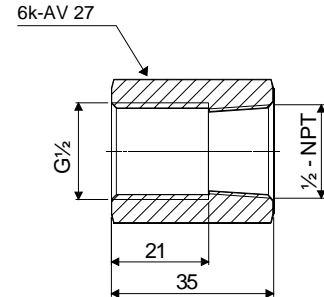

Thread $\frac{1}{2}$ - 14 NPT, female
Order code : M1050471

Figure 1-2 Modification adapters of the process connection, types VT_e4 ... VTA_e7

Process couplings

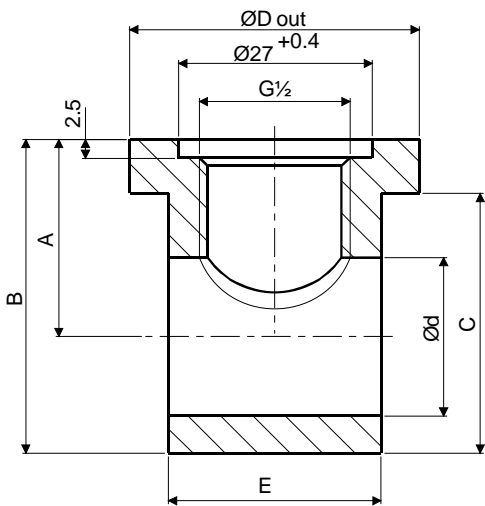

Pipe size	Dim. ØD out	Dim. A	Dim. B	Dim. C	Dim. Ø d	Dim. E	Order code
DN15	40	27.5	43.5	36	22	29.5	M1050395
DN20	40	30.5	49	42	27.5	26	M1050396
DN25	50	33.5	55.5	48	34	29.5	M1050397

Other sizes, please contact Satron Instruments Inc.

Figure 1-3
T-coupling DIN 3852-X-G $\frac{1}{2}$, sizes DN15 - 25

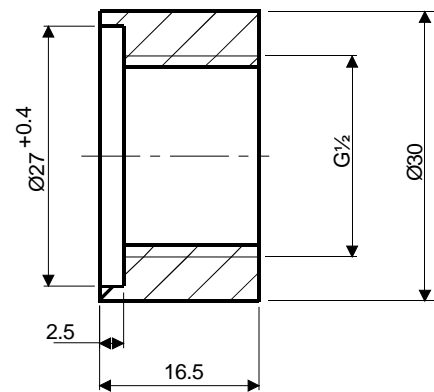

Order code : M1050369

Figure 1-5 Coupling DIN 3852-X-G $\frac{1}{2}$

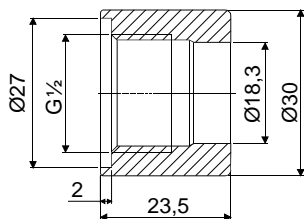

Ordercode: M1050515

Figure 1-4
Coupling G $\frac{1}{2}$ (for process connection code 5)

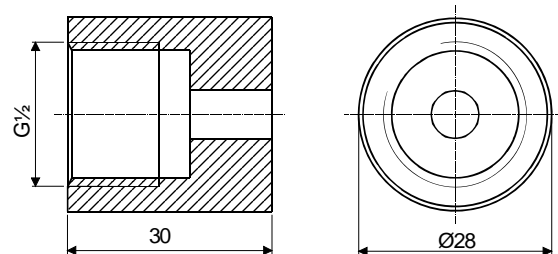

Order code : M1050367

Figure 1-6 Coupling DIN 16288 - G $\frac{1}{2}$

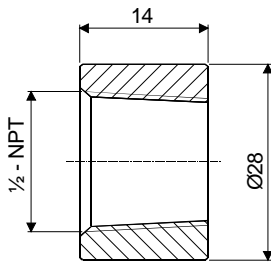

Order code: M1050368

Figure 1-7 Process coupling 1/2 - NPT

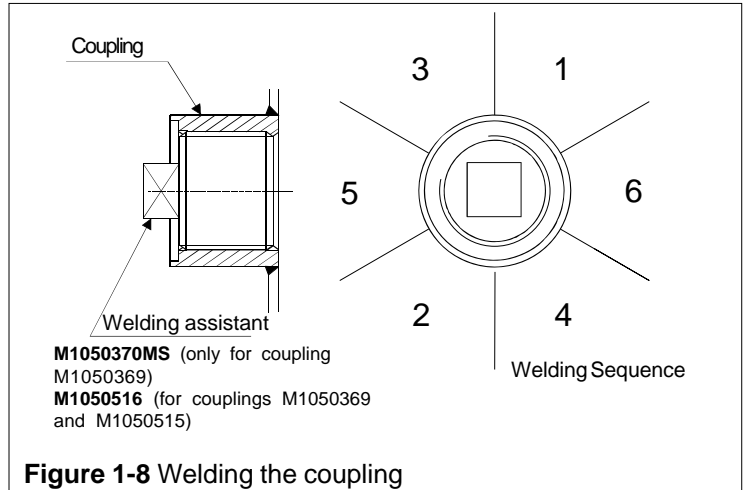

Figure 1-8 Welding the coupling

1.1 Mechanical installation

1.1.1 Recommended mounting positions

- Process connection direction: horizontal
- Cable entry direction: from below
- Connector coupling direction, calibration direction: horizontal

Other considerations:

- In outdoor installations you should make sure that water condensed from e.g. a steam line will not freeze and, by expanding, damage the transmitter's sensor diaphragm. For instance, this can be avoided by installing heat insulation up to the sensor diaphragm.

1.1.2 Impulse piping

The process medium and the transmitter's position in relation to the process pipe determine the impulse piping line.

- For liquid and steam pressure measurements it is preferable to install the transmitter below orifice plate to prevent the formation of disturbing gas bubbles in the impulse piping.

If the transmitter has to be installed above the process pipe for reasons of accessibility or for some other compelling reasons, it is recommendable to provide the piping with a gas seal to avoid disturbance.

- Mounting the transmitter above the process pipe in gas pressure measurement will eliminate disturbances caused by condensing liquid.

- Steam should not be admitted to the transmitter's sensing element. See installation examples 1-9 c and d.

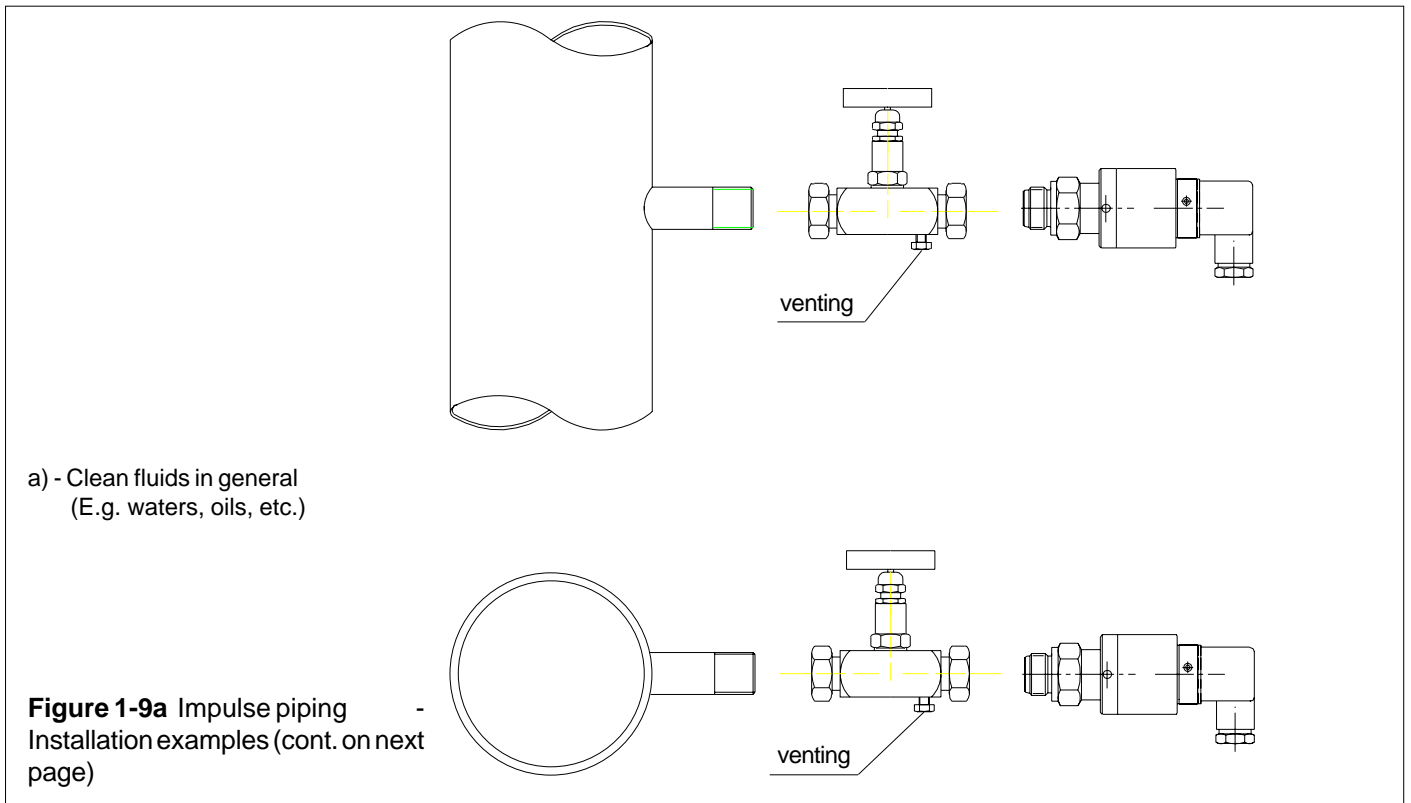

Figure 1-9a Impulse piping - Installation examples (cont. on next page)

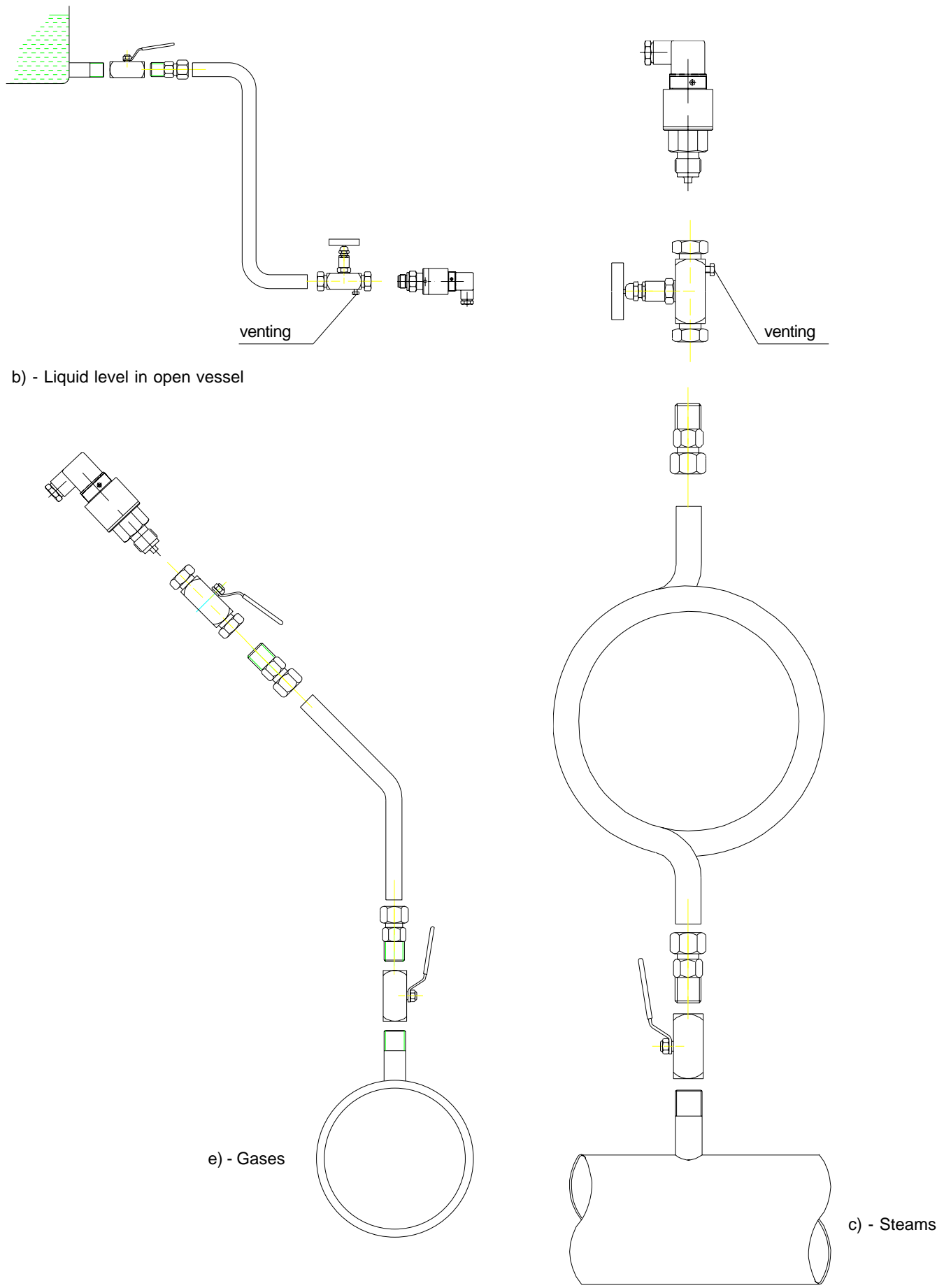

Figure 1-9b Impulse piping
- Installation examples (cont. on next page)

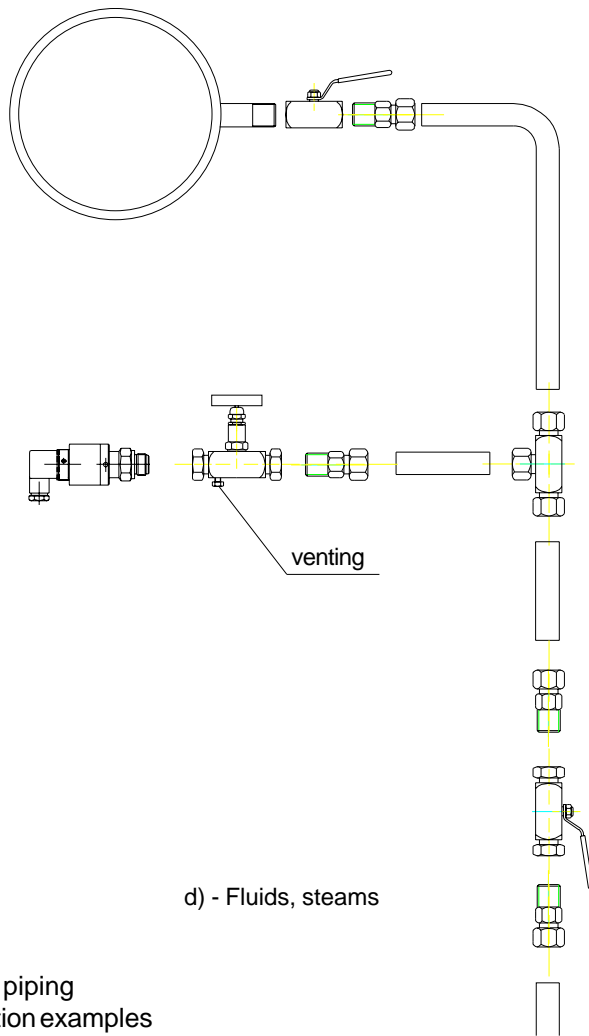

Figure 1-9c Impulse piping
- Installation examples

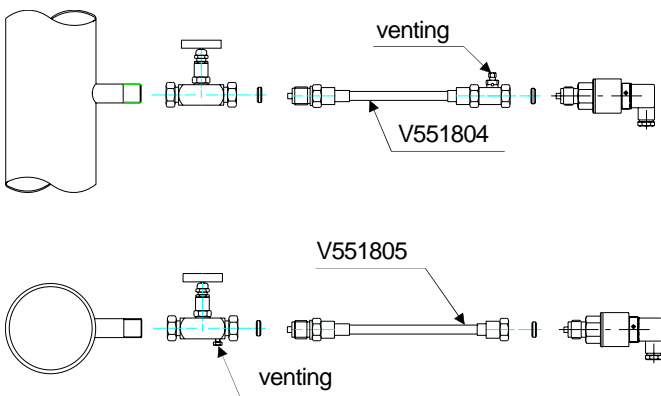

Figure 1-10 Damping hose for protecting the sensor
- Order number T551804, with venting
- Order number T551805, without venting

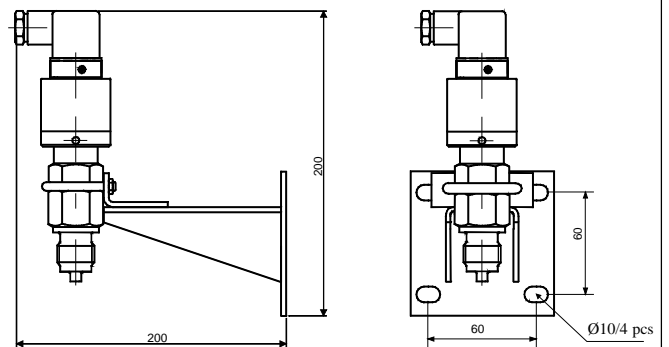

Figure 1-11 Mounting bracket for VT_e transmitter
- Order number M820289

SATRON VT_e pressure transmitter

1.2 Electrical connections

Supply voltage and load of the transmitter according to the figure 1-14.

We recommend shielded twisted-pair cable as signal cable.

The signal cable should not be installed near high-voltage cables, large motors or frequency converters.

The shield of the cable is grounded at the power supply end or according to the recommendations of the manufacturer of the used control system.

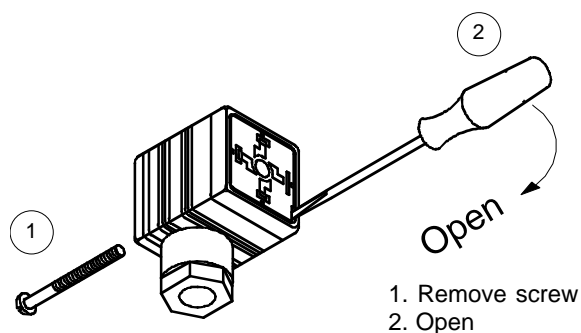

Figure 1-12 Removing the PLUG junction box

10044093

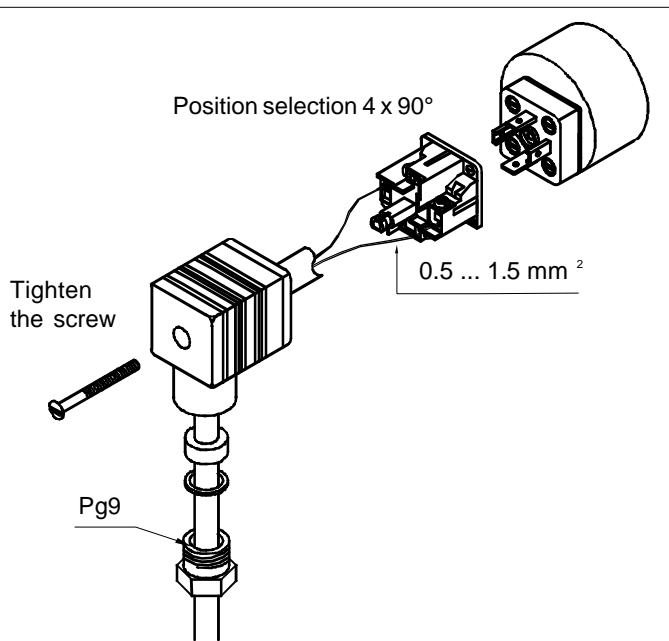
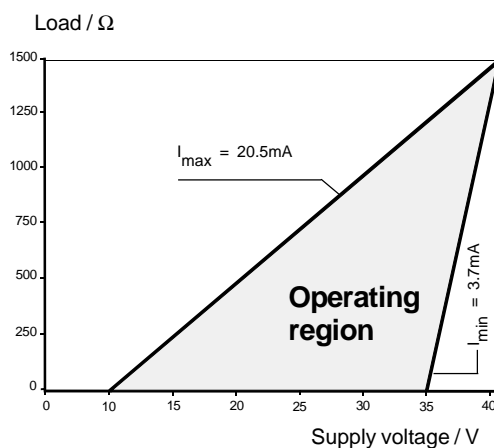

Figure 1-13 Adjusting the junction box position

10044092



$$R_{\max} = \frac{\text{Supply voltage} - 10V}{I_{\max}}$$

$I_{\max} = 20.5\text{mA}$ using HART®-communication

$I_{\max} = 23\text{mA}$ (when the alarm current 22.5mA is on)

Figure 1-14 Supply voltage and load capacity

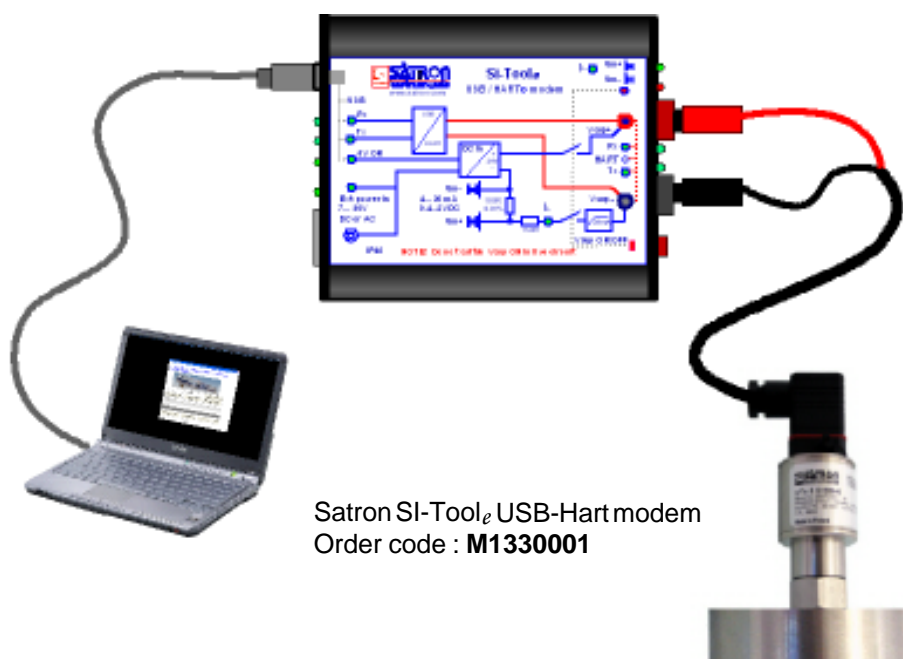

Satron SI-Tool_e USB-Hart modem
Order code : **M1330001**

Figure 1-15 Connection with Satron SI-Tool_e USB-Hart modem

1320354005

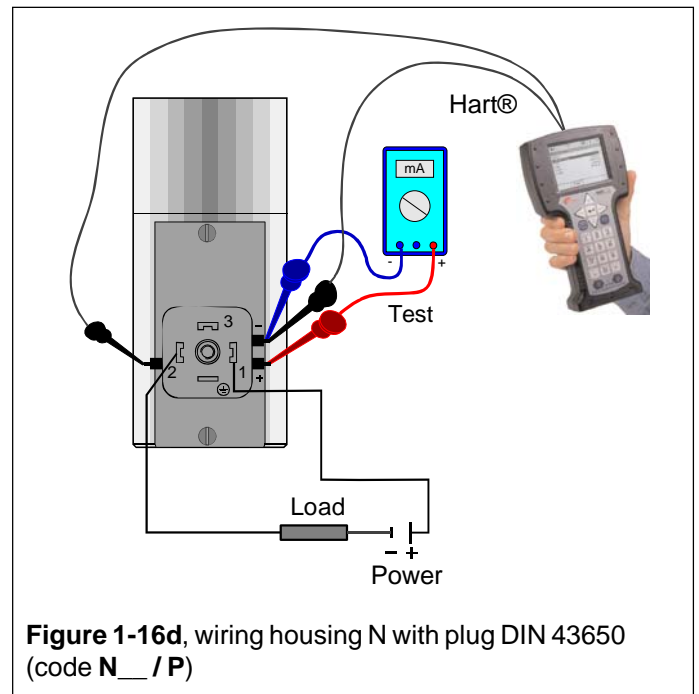
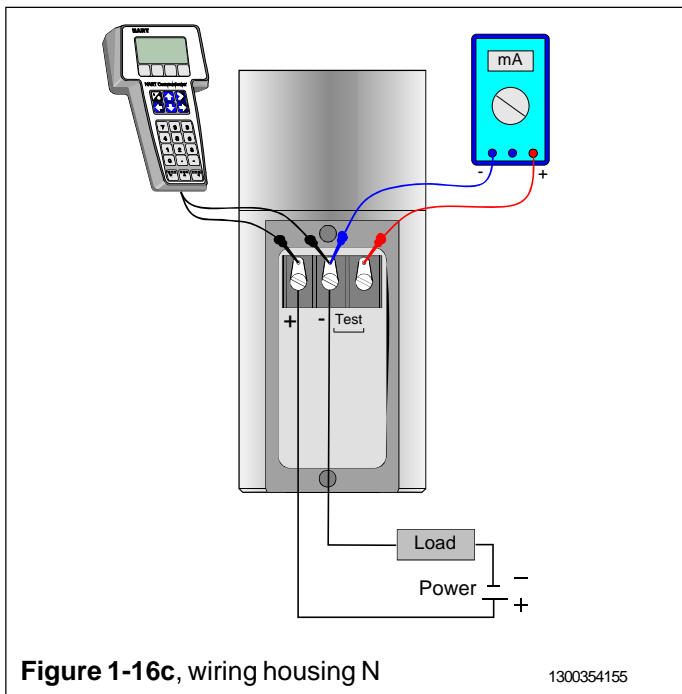
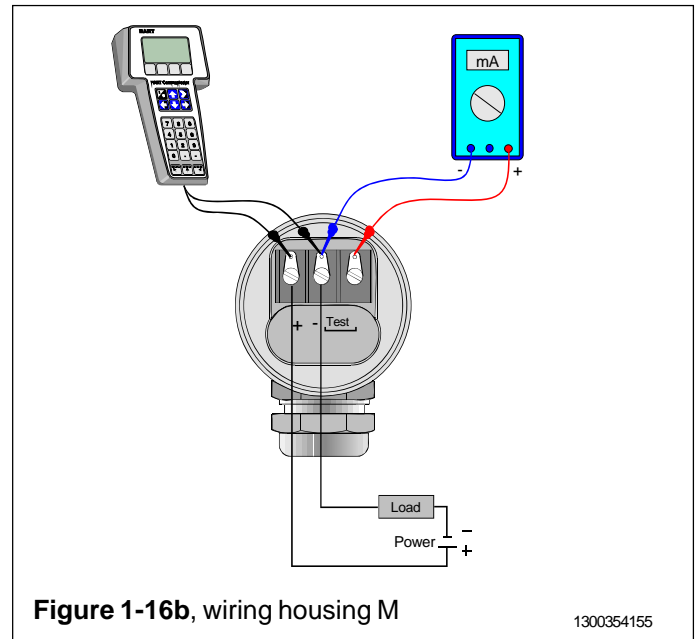
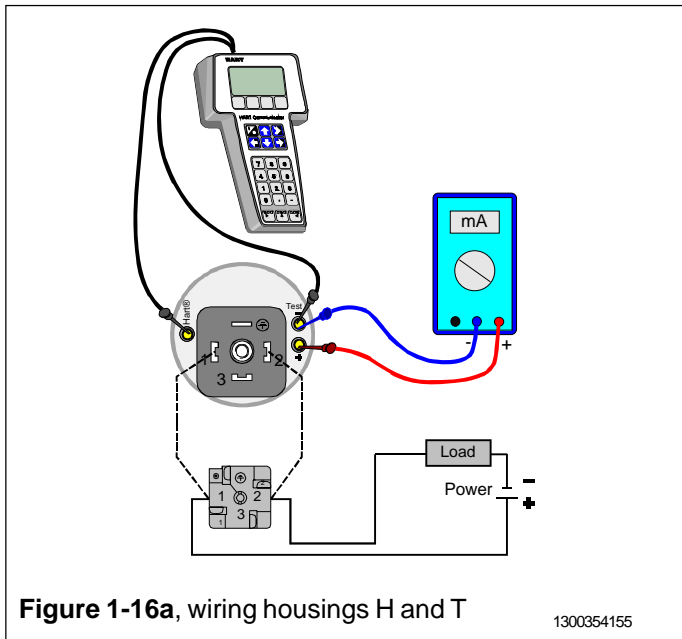

2 SETTING UP

Setting up is dependent on type of user interface and loaded description **VALMET** or **SATRON**. Also must be noted that when the older **VALMET** description is in use then the transmitter must be configured so that it can operate with the old **VALMET** description.

The change from description to another is made by writing to **MESSAGE**-field either. **VALMET** or **SATRON** (Note, capital letters and dot in front).

After writing the message the new description will be activated by switching transmitter's power **OFF** and **ON** again.

SATRON VT_e pressure transmitter

2.1 Using the 275 user interface

Operation keys

The six operation keys are located above the alphanumeric keyboard:

The ON/OFF key (**I/O**) switches the user interface on and off. When you switch the user interface on, it starts looking for a HART® transmitter connected to it. If the transmitter is not found, the message “**No Device Found. Press OK**” will be displayed.

The **ONLINE** menu is displayed when the user interface finds the transmitter.

(**^**) This key allows you to move upwards in menus and scroll lists forwards.

(**v**) This key allows you to move downwards in menus and scroll lists backwards.

(**<**) This two-function key allows you to move the cursor to the left and to go back to a previous menu.

(**>**) This two-function key allows you to move the cursor to the right and to select a menu option.

(**>>>**) The quick-selection key will start the user interface and display the quick-selection menu. You can define the desired menu as quick-selection menu.

Function keys

With function keys F1, F2, F3 and F4 you can perform the program functions displayed above each function key. When you move in the software menus, the functions of these keys will change in accordance with the currently selected menu.

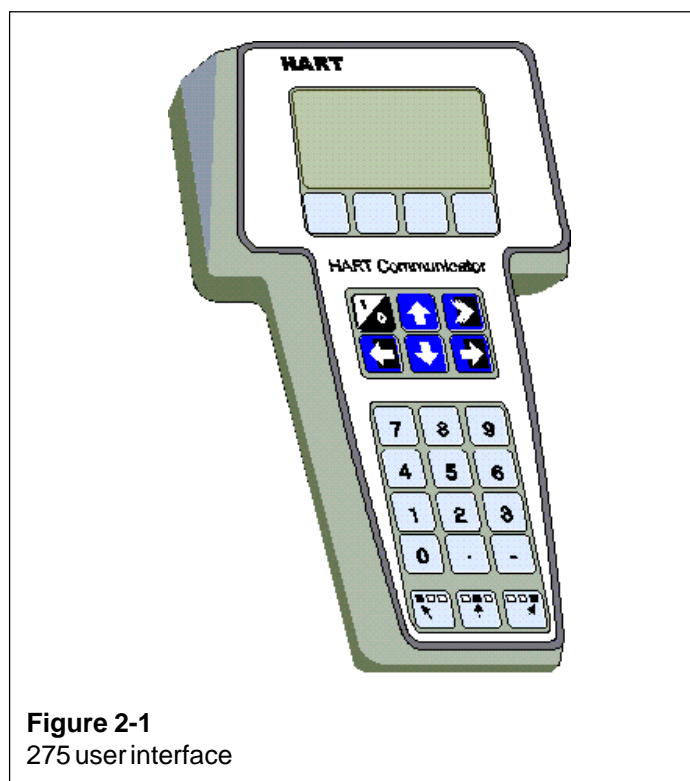

Figure 2-1
275 user interface

2.2 Setting up through HART® 275 user interface and VALMET description

After installing and connecting the transmitter, connect the user interface to the transmitter. The following menu is displayed:

- 1 **Measurement**
- 2 **Configuration**
- 3 **Information**
- 4 **Diagnostics**

To change the measuring range, unit damping time constant to output mode (linear/square-root), select **Configuration**.

The following menu is then displayed:

- 1 **Range values**
- 2 **Detailed config**

To change the measuring range, select **Range values**.

The selection displays the following menu:

- 1 **LRV** (lower range value)
- 2 **URV** (upper range value)
- 3 **LSL** (lower sensor limit, factory setting)
- 4 **USL** (upper sensor limit, factory setting)
- 5 **Min span** (minimum span)
- 6 **Apply values**

To change the measurement unit, damping time constant or output mode, select **Detailed config** from the **Configuration** menu.

The selection displays the following menu:

- 1 **Damping**
- 2 **Pres. unit**
- 3 **Tempr. unit**
- 4 **Alarm current**
- 5 **Write protect**
- 6 **Lin. func**
- 7 **Diff EI status**
- 8 **Burst mode**
- 9 **Burst option**
- Poll addr**
- Tag**
- User function**
- User funct. setup**

After these activities or if the transmitter is supplied with the ready configuration you must correct a zero error of the transmitter in a final installation position.

Press **Diagnostics** and **PV Zero calibr.**

The selection displays the following menu: **Give correct value for Zero pressure in ...**

The current zero point will be shown in display and the final zero error correction can be done.

2.3 Using the 375 user interface



Figure 2-2
375 user interface

2.4 Setting up through HART® 375 user interface and SATRON description

After installing and connecting the transmitter, connect the user interface to the transmitter. The following menu is displayed: **Main menu**. To select the **HART Application**.

The following menu is then displayed:

- 1 **Measurement**
- 2 **Configuration**
- 3 **Information**
- 4 **Diagnostics**
- 5 **Review**

To change the measurement unit, damping time constant or output mod, select **Configuration**.

The following menu is then displayed:

- 1 **Range values**
- 2 **Output**
- 3 **Transfer function**
- 4 **General setup**

To change the measurement unit, select **Range values**.

The following menu is then displayed:

- 1 **LRV**
- 2 **URV**
- 3 **LSL**
- 4 **USL**
- 5 **Min span**
- 6 **Apply values**

To change the damping time constant, select **Output** from the **Configuration** menu.

The following menu is then displayed:

- 1 **Damping**
- 2 **Alarm current**

To change the output mode, select **Transfer function** from the **Configuration** menu.

The following menu is then displayed:

- 1 **Lin. func**
- 2 **User function data**

After these activities or if the transmitter is supplied with the ready configuration you must correct a zero error of the transmitter in a final installation position.

The First press **Diagnostics** and then **Sensor trim** and then **Zero trim**

The following text is then displayed : *WARN-Loop be removed from automatic control*

The final zero error correction can be done to select **ABORT** or **OK** on the display .

2.5 Setting-up with Satron-pAdvisor Service Software

When you will have available all the operations of the Smart transmitter, we recommend the use of Satron-pAdvisor Service Software and Satron SI-Tool_e USB-Hart-modem in setting-up.

Test connections for configuration and pressure/ output current values checking and calibration and for SENSOR TRIM function

Recommended equipment for calibration

Satron-pAdvisor service software for SATRON Smart transmitter (can be loaded free of charge from www.satron.com)

PC: operating system Win-98, Windows 2000 or Windows XP)

DMM: Digital multimeter, basic DCV accuracy better than 0,01 % of reading (for example Fluke 8840A, Keithley 2000)

Cal. pressure generation and measurement device (accuracy better than 0,03 % of reading)

USB-Hart modeemi, Satron SI Tool_e, tilauskoodi: **M1330001**

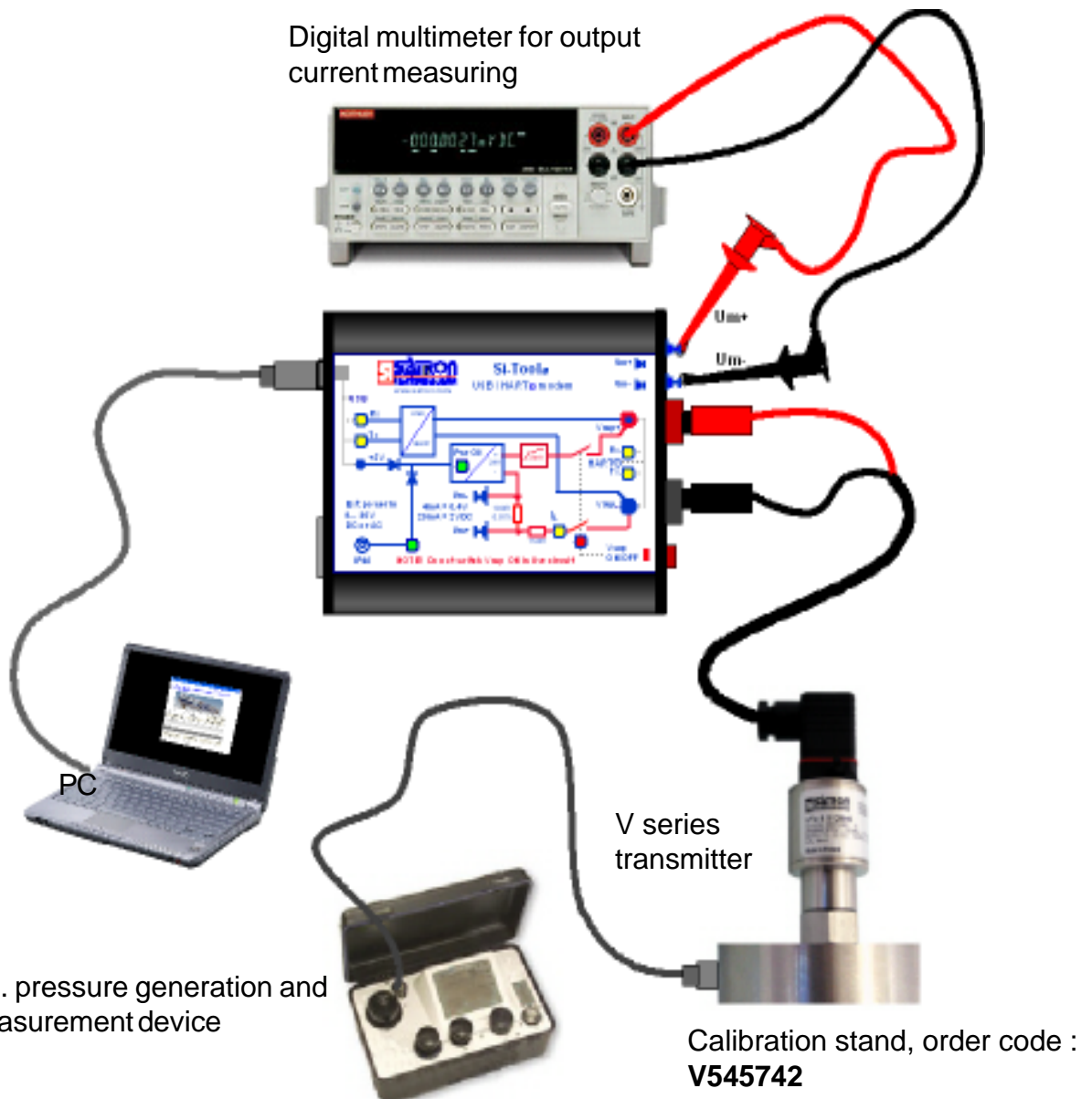
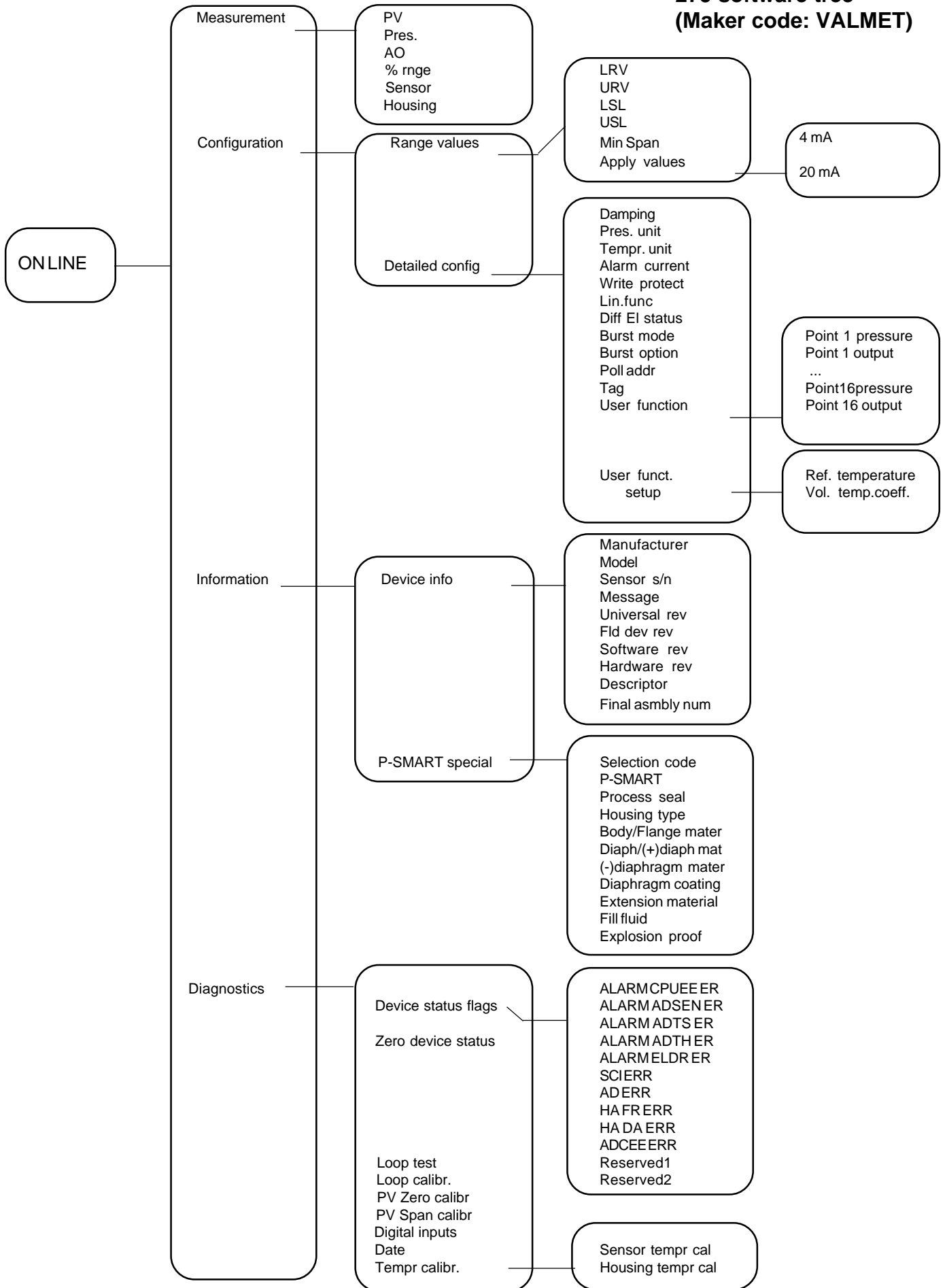
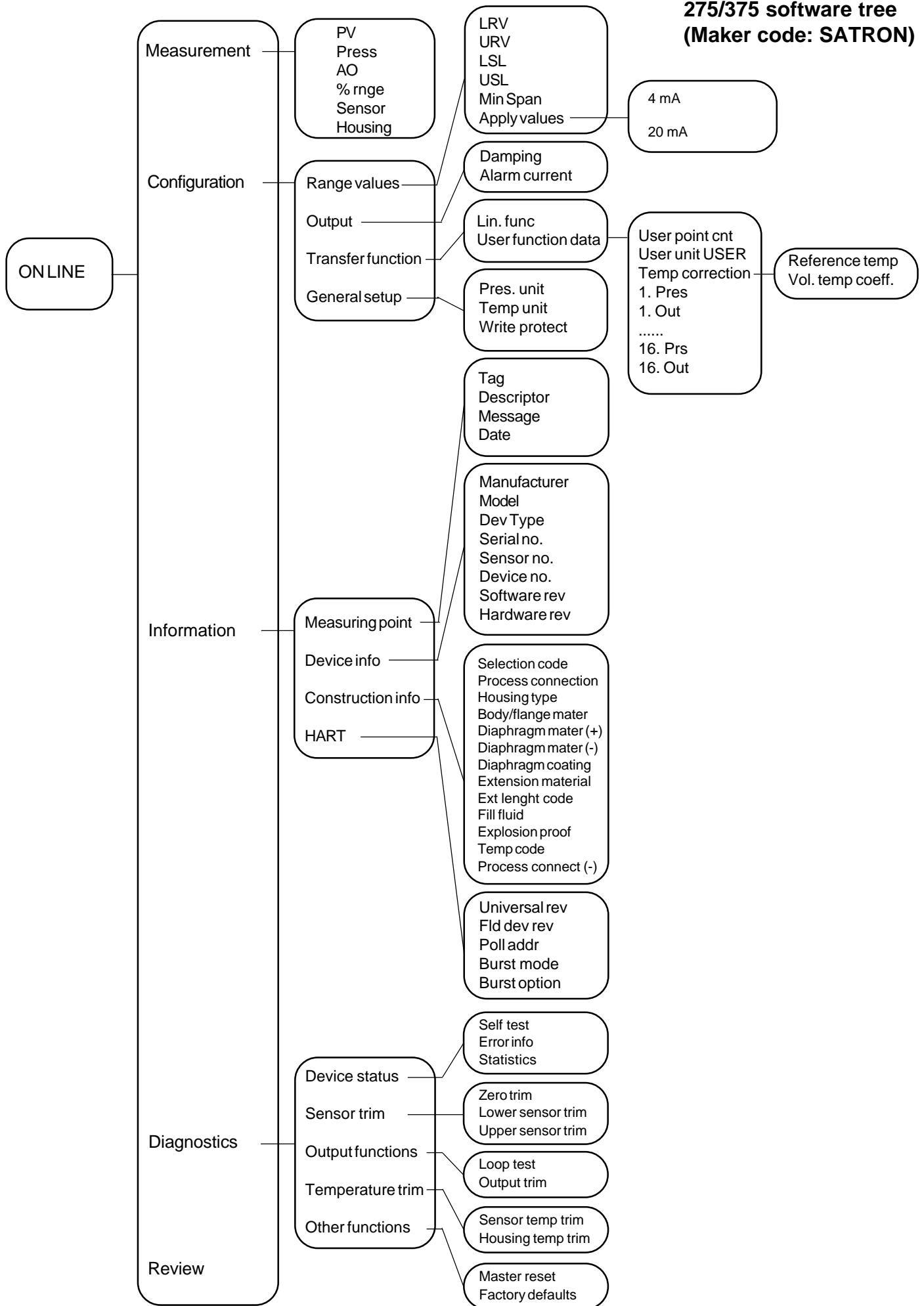

Figure 2-3 Calibration connections window

**275 software tree
(Maker code: VALMET)**



**275/375 software tree
(Maker code: SATRON)**



3. CONSTRUCTION AND OPERATION

Sensor Module

The piezoresistive sensor, which has a silicone oil fill, is isolated from the process with a diaphragm. Sensor pressure and temperature are measured with a 24-bit AD converter. Linearity and temperature effects are digitally corrected.

The **sensor** converts pressure to electrical signal. The conversion is carried out through a Wheatstone bridge supplied with direct current. The elastic displacement produced in the bridge by the pressure causes bridge unbalance which is measured as a DC voltage signal.

Electronics Module

The electronics module converts the process pressure signal from the sensor module to 4-20 mA output signal. The conversion can be made in linear, square root or inverted mode, or it can be done through user-selectable pressure/output point pairs (2-16 points).

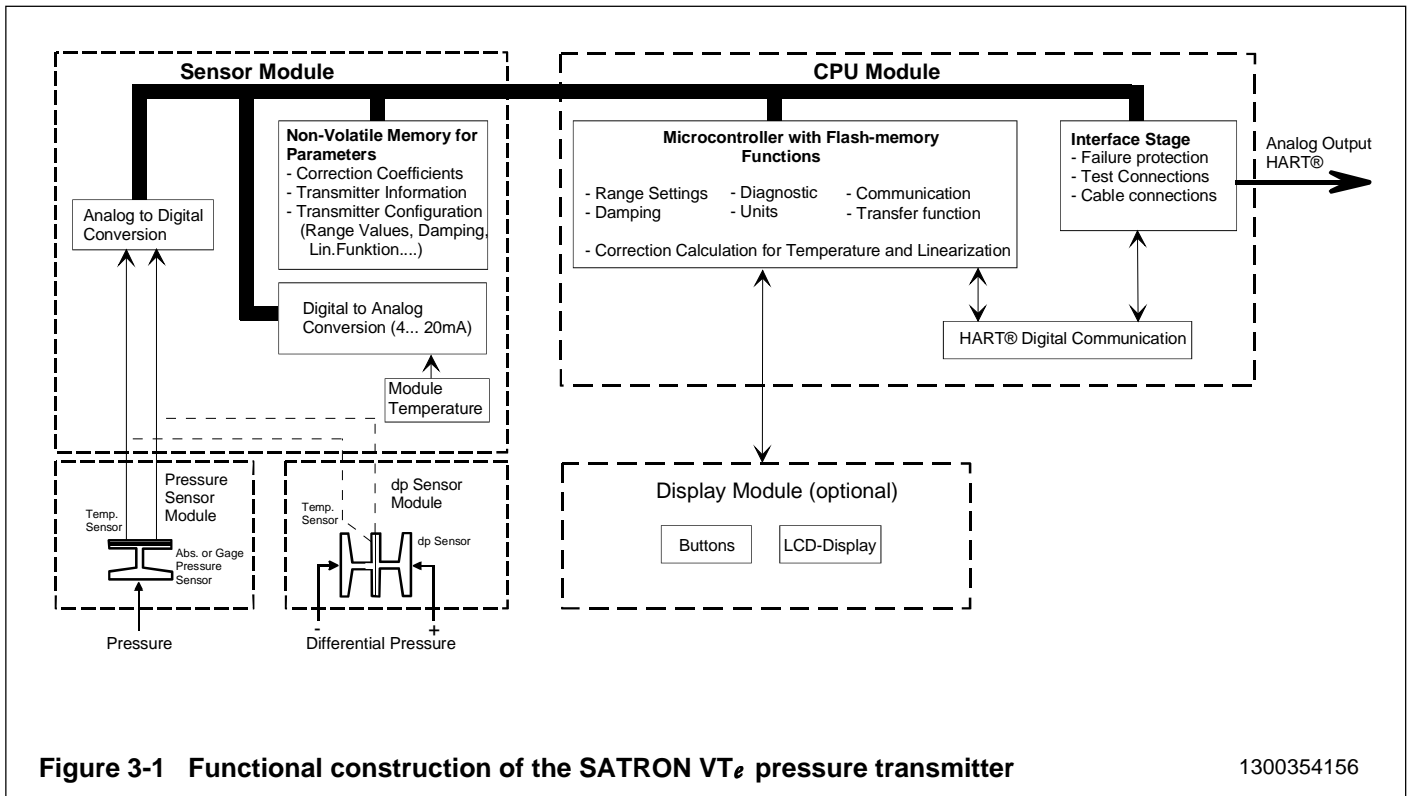

1300354156

4. PARTS LIST

When ordering spares, please quote this document's number BPH711AV and date 15.2.2013, the name and order number of the required part, and the transmitter's serial number. Parts indicated with asterisk (*) as well as screws, nuts and seals (packings) are spare parts.

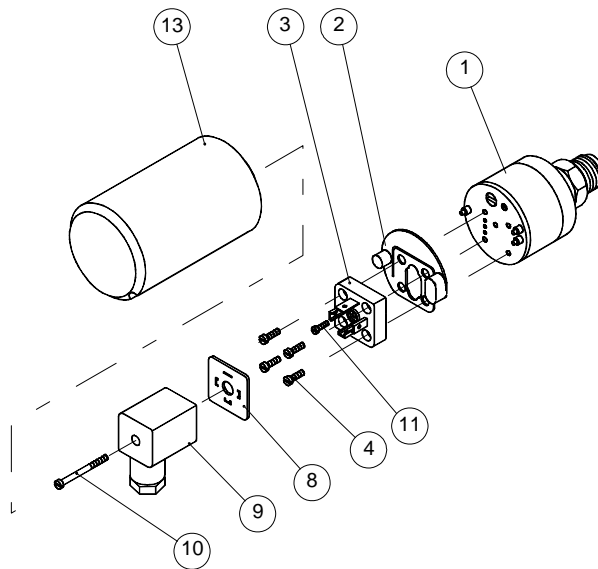

Figure 4-1 Parts list: Housing with PLUG connector, codes H

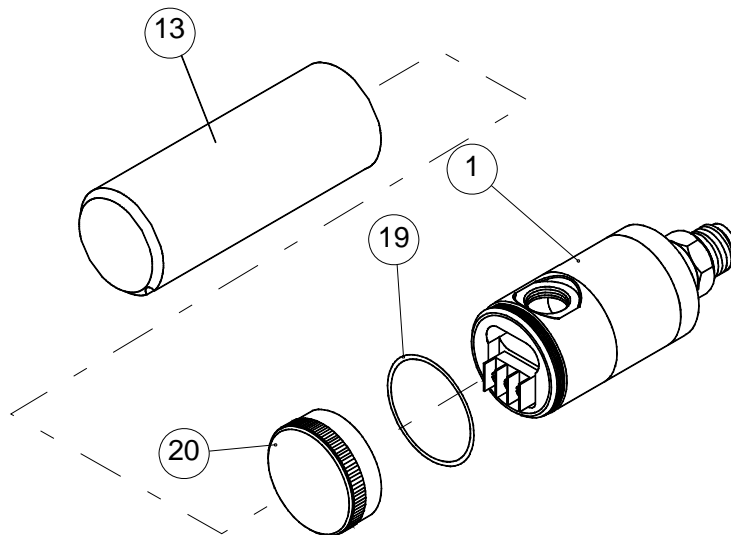

Figure 4-2 Parts list: housing with junction box / terminal strip, code M

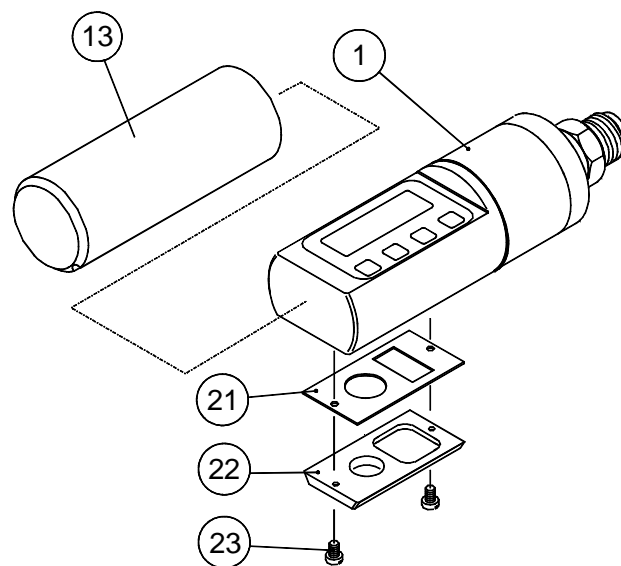

Figure 4-3 Parts list: housing with junction box / terminal strip with display , code N

Number	Name	Order number	Number	Name	Order number
1	Sensing element				
2	Seal	T1300207	* 13	Protection cup, housing H and M	T1300295
* 3	Device plug DIN43650	72900114	* 13	Protection cup, housing N	T1300400
4	Cylinder-head screw M3 x 10 SFS2179 Zne	51603021			
			* 14	Coupling	see chapter 1.1.3
7	O-ring 17 x 2, Viton®	80031720	19	O-ring, 42x2 FPM (Viton®)	80013800
	O-ring 17 x 2, EPDM	80011720	* 20	Cover M	T1300256
8	Seal GDM3-17,silicone	72900116	21	Seal, Silicone rubber	T1300387
* 9	Wiring box GDM3009, DIN43650	72900111	* 22	Back plate V	T1300391
10	Cylinder-head screw S M3 x 35 SFS2179 A4	51723053	23	Fastening screw M4	T1325347
11	Cylinder-head screw S M3 x 4 VSM 13302 Zne	51613009			



Satron Instruments Inc.
P.O.Box 22, FIN-33901 Tampere, Finland
Tel.int. +358 207 464 800, Telefax +358 207 464 801